

Parts Catalogue

FX481V- S01

PARTS CATALOG INTRODUCTION

This parts catalog lists parts and sub-assemblies provided as service parts. When it becomes necessary to replace parts, always use KAWASAKI GENUINE PARTS which have passed strict inspection which guarantees quality and performance.

1. HOW TO ORDER PARTS

- 1) When ordering the parts, be sure to use the parts catalog corresponding to the product code. Check the product revision codes on the product and the catalog.

Product Code (example) : FA130D-AA00
 Product Revision Code

- 2) Specify the part code (all digits) exactly as listed in this catalog on your parts order.
- 3) The parts not shown in the illustrations of this catalog are not sold separately; only the complete units or next higher assemblies illustrated are supplied as the service parts.

2. EXPLANATION OF PARTS CATALOG FORMAT

1 FJ180V- M24

2 B-08. ELECTRIC-EQUIPMENT

5 E0160-B181B

7 Quantity

Ref. No.	Part No.	Description	Quantity
14091	14091-2141	COVER	1
19073	19073-2241	INSULATOR	1
21169	21169-2077	TERMINAL	1
21171	21171-2267	COIL-ASSY-IGNITION	1
21194	21194-2355	FLYWHEEL-COMP	1
29011	29011-2390	WIRE-LEAD	1
92038	92038-2107	KEY	1
92070	92070-2119	PLUG-SPARK(BPRSES(NGK)	1
92154	92154-2014	BOLT,4X18	1
92154A	92154-2018	BOLT,6X20	2
92154B	92154-2017	BOLT,12X30	1
92200	92200-2183	WASHER,4.5X8X0.5	1
92210	92210-2126	NUT,M4	1

1) Product Code

This code describes the product code covered by this catalog. The product revision code, which is a part of the product code, is omitted.

2) Part Group Title

This title is the representative name for the group of parts illustrated on the page.

3) Reference Number

The reference numbers are shown on the illustration and the list as the link between them.

4) Part Number

This is the key of your parts ordering. Three kinds of part number are used in this catalog.

a. Structure 1

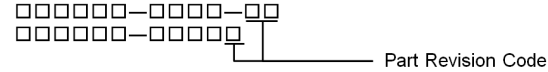

b. Structure 2



c. Standard Hardware Number

(for bolts, nuts, washer, or the like)



5) Description and Additional Information

The part name, the location, the size, and the serial number as additional information, etc. are described here. Use them to find out and check the part required.

When a part number is changed without change of the product revision code and the changed parts are not interchangeable, the serial number of the product is noted as follows;

- (- FA130 - 100001) Affected units are from beginning of the product of the product code up to and including this serial number.
- (FA130 - 100002 -) Affected units are from this serial number and above.
- (FA130 - 100002 - FA130 - 110001) Affected units are in this serial number range.

6) Quantity

The figure shows quantity of the part required at the indicated position on the illustration and for the specified product revision code.

The asterisk (*) on this column means the part can be used as the substitute on the product and is supplied until the stock is exhausted.

Note: Some small parts will be supplied by units.

Example: If six (6) bolts are ordered and the minimum quantity per unit is five (5), two (2), units of the bolt will be delivered.

7) Product Revision Code

This Code indicates an important change which affects the service parts interchangeability.

3. ABBREVIATIONS

#	Number	FR	Front	RH	Right Hand
&	And	G	Gram	RPM	Revolutions Per Minute
(+)	Plus	HEX	Hexagonal	RR	Rear
(-)	Minus	ID =	Inside Diameter	STD	Standard
2ND	Second	IN	Inch	T	Teeth
3RD	Third	L =	Length	T =	Thickness
4TH	Fourth	LH	Left Hand	U/S	Under Size
A	Ampere	LWR	Lower	UPP	Upper
AR	As Required	MM	Millimeter	V	Volt
ASSY	Assembly	O/S	Over Size	W	Watt
CNT	Center	OD =	Outside Diameter		
COMP	Complete	REF	Reference		

E0110-A931B

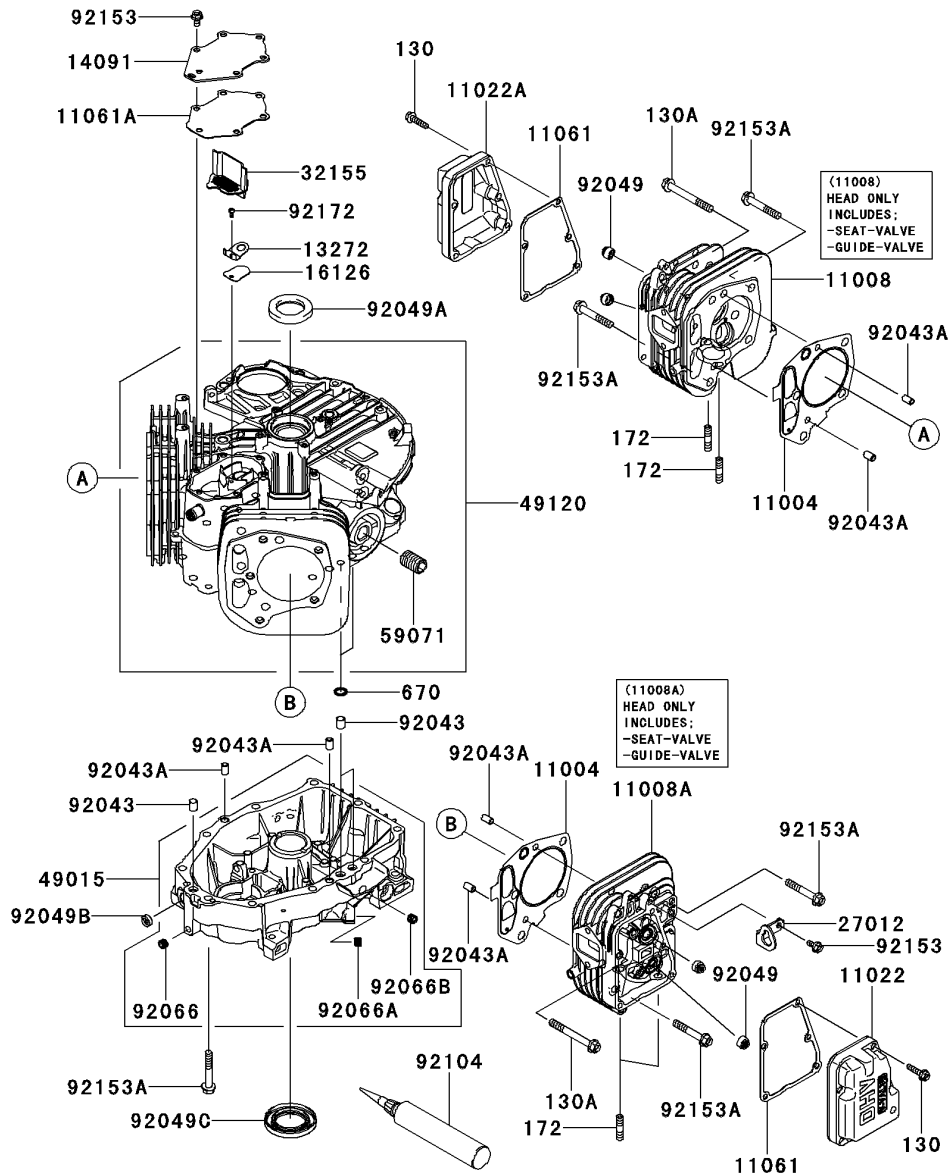

B-03. CYLINDER/CRANKCASE

Ref. No.	Part No.	Description	Quantity
			E
11004	11004-7027	GASKET-HEAD	2
11008	11008-7050	HEAD-COMP-CYLINDER,#1	1
11008A	11008-7051	HEAD-COMP-CYLINDER,#2	1
11022	11022-0038	CASE-ROCKER,#2	1
11022A	11022-0710	CASE-ROCKER,#1	1
11061	11061-7083	GASKET,CASE-ROCKER	2
11061A	11061-7094	GASKET,BREATHER	1
13272	13272-1374	PLATE	1
14091	14091-7064	COVER,BREATHER	1
16126	16126-7020	VALVE,BREATHER	1
27012	27012-0721	HOOK,LIFT	1
32155	32155-7003	PIPE,BREATHER	1
49015	49015-0019	COVER-CRANKCASE	1
49120	49120-0731	CRANKCASE-COMP	1
59071	59071-0733	JOINT	1
92043	92043-0858	PIN	3
92043A	92043-1263	PIN,6.2X8X14	6
92049	92049-7001	SEAL-OIL,RVC2 6X11X10.2	4
92049A	92049-7016	SEAL-OIL,SD 35X48X8 R HS	1
92049B	92049-7019	SEAL-OIL,SO 8X14X5 HS	1
92049C	92049-7028	SEAL-OIL,38X62X8MTCLV	1
92066	92066-0761	PLUG	1
92066A	92066-0762	PLUG	1
92066B	92066-2223	PLUG	1
92104	92104-0007	GASKET-LIQUID,TB1217H	AR
92153	92153-7043	BOLT,6X12	7
92153A	92153-7054	BOLT,8X50	14
92172	92172-0870	SCREW,4X8	1
130	130BA0625	BOLT-FLANGED,6X25	10
130A	130CA0870	BOLT-FLANGED,8X70	6
172	172BA0822	BOLT-STUD,8X22	4
670	670B2011	O RING,11MM	2

E0120-A530B

B-04. PISTON/CRANKSHAFT

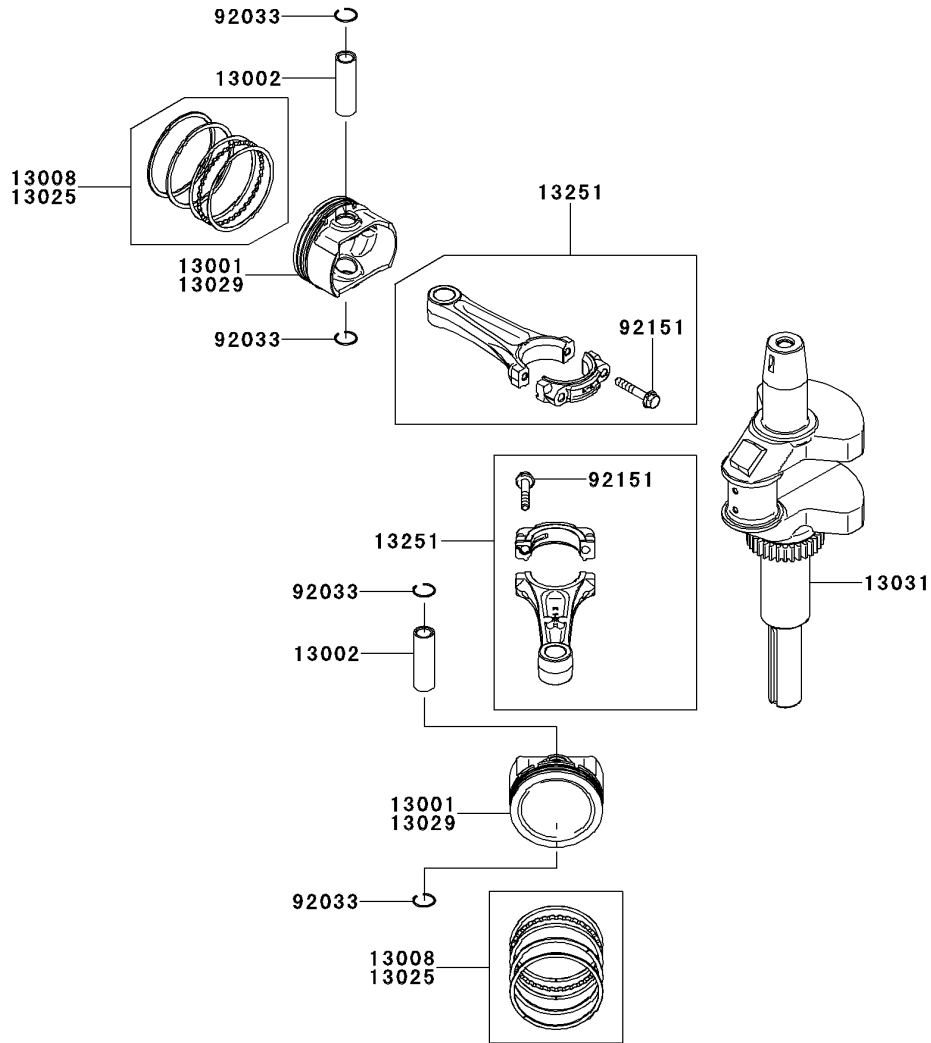

Ref. No.	Part No.	Description	Quantity
			E
13001	13001-7031	PISTON-ENGINE	2
13002	13002-7001	PIN-PISTON	2
13008	13008-7006	RING-SET-PISTON	2
13025	13025-7010	RING-SET-PISTON L,0.50	AR
13029	13029-7011	PISTON-ENGINE L,0.50	AR
13031	13031-0814	CRANKSHAFT-COMP	1
13251	13251-7021	ROD-ASSY-CONNECTING	2
92033	92033-0725	RING-SNAP	4
92151	92151-7017	BOLT,6X35	4

E0130-A216V

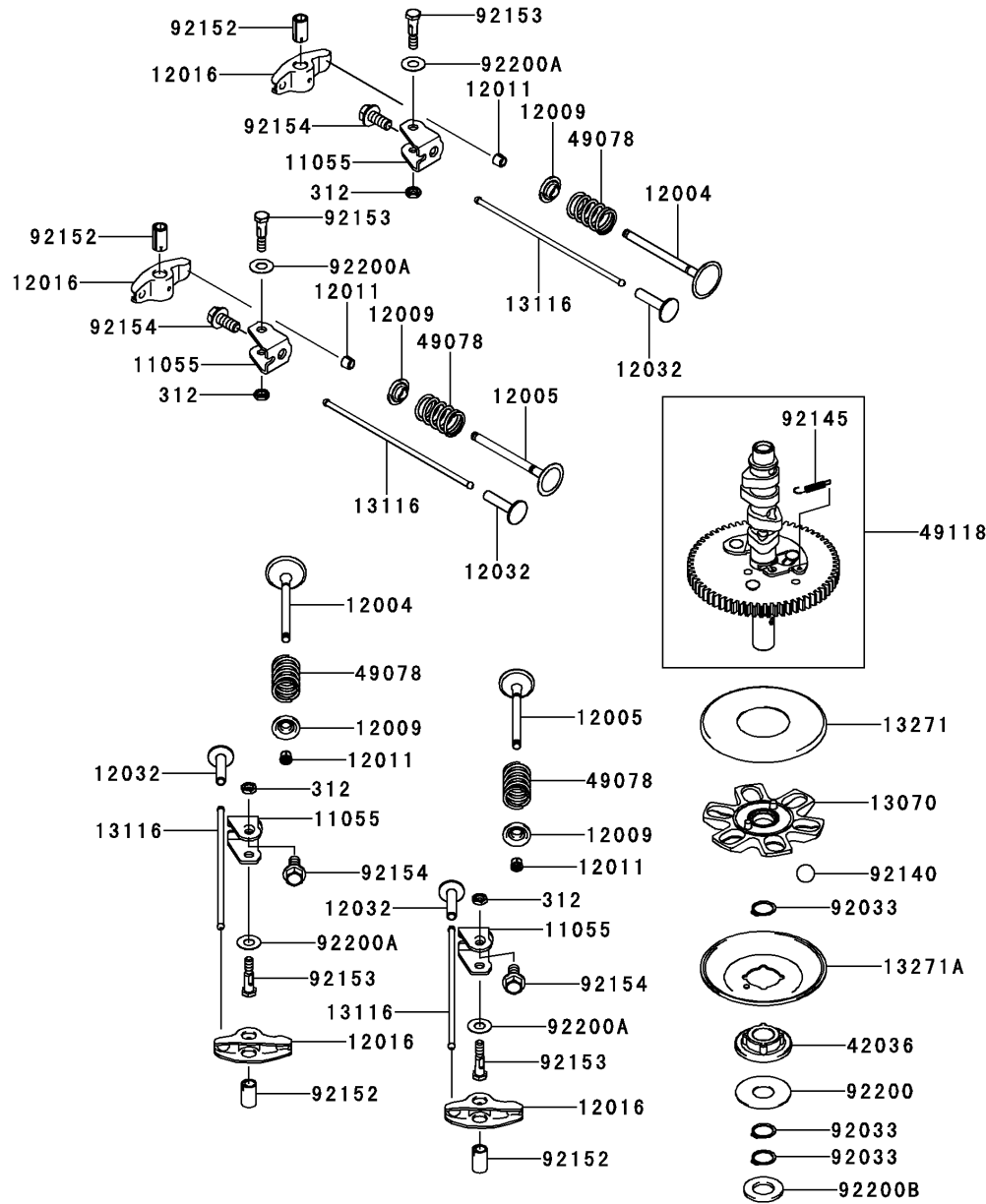

B-05. VALVE/CAMSHAFT

Ref. No.	Part No.	Description	Quantity
			E
11055	11055-7009	BRACKET	4
12004	12004-7009	VALVE-INTAKE	2
12005	12005-0735	VALVE-EXHAUST	2
12009	12009-7001	RETAINER-VALVE SPRING	4
12011	12011-2056	COLLET	8
12016	12016-0040	ARM-ROCKER	4
12032	12032-7001	TAPPET	4
13070	13070-7017	GUIDE,GOVERNOR	1
13116	13116-7008	ROD-PUSH	4
13271	13271-7007	PLATE	1
13271A	13271-7021	PLATE,GOVERNOR	1
42036	42036-7021	SLEEVE	1
49078	49078-7002	SPRING-ENGINE VALVE,IN	4
49118	49118-0809	CAMSHAFT-COMP	1
92033	92033-0727	RING-SNAP	3
92140	92140-7005	BALL	6
92145	92145-1653	SPRING	1
92152	92152-1689	COLLAR	4
92153	92153-7100	BOLT,6X29.5	4
92154	92154-1267	BOLT,8X18.2	4
92200	92200-0945	WASHER,16X42X0.91	1
92200A	92200-2151	WASHER,8.1X18X0.5	4
92200B	92200-7048	WASHER,16.3X30X2.28	1
312	312AA0600	NUT-HEX,6MM	4

E0140-A507A

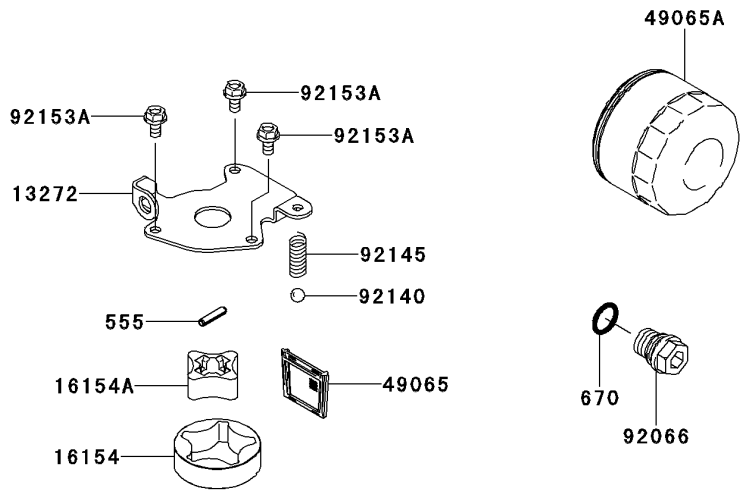
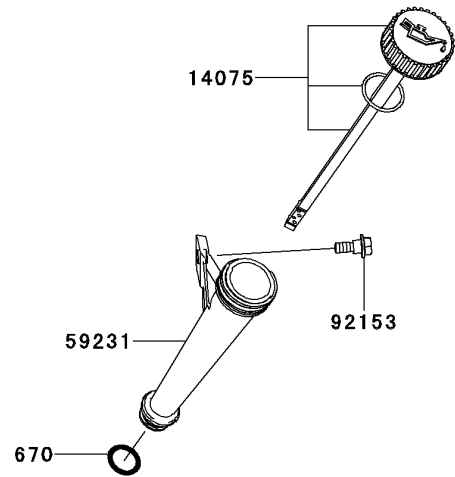

B-06. LUBRICATION-EQUIPMENT

Ref. No.	Part No.	Description	Quantity
			E
13272	13272-7011	PLATE,ROTOR	1
14075	14075-0037	CAP-ASSY	1
16154	16154-7010	ROTOR-PUMP,OUTER	1
16154A	16154-7011	ROTOR-PUMP,INNER	1
49065	49065-7006	FILTER-OIL	1
49065A	49065-7007	FILTER-OIL	1
59231	59231-0712	FILLER	1
92066	92066-0774	PLUG	1
92140	92140-7003	BALL,STEEL,13/32	1
92145	92145-1658	SPRING	1
92153	92153-7007	BOLT,FLANGED,6X16	1
92153A	92153-7043	BOLT,6X12	3
555	555A0420	PIN-SPRING,4X20	1
670	670D2016	O RING,16MM	2

E0150-B304A

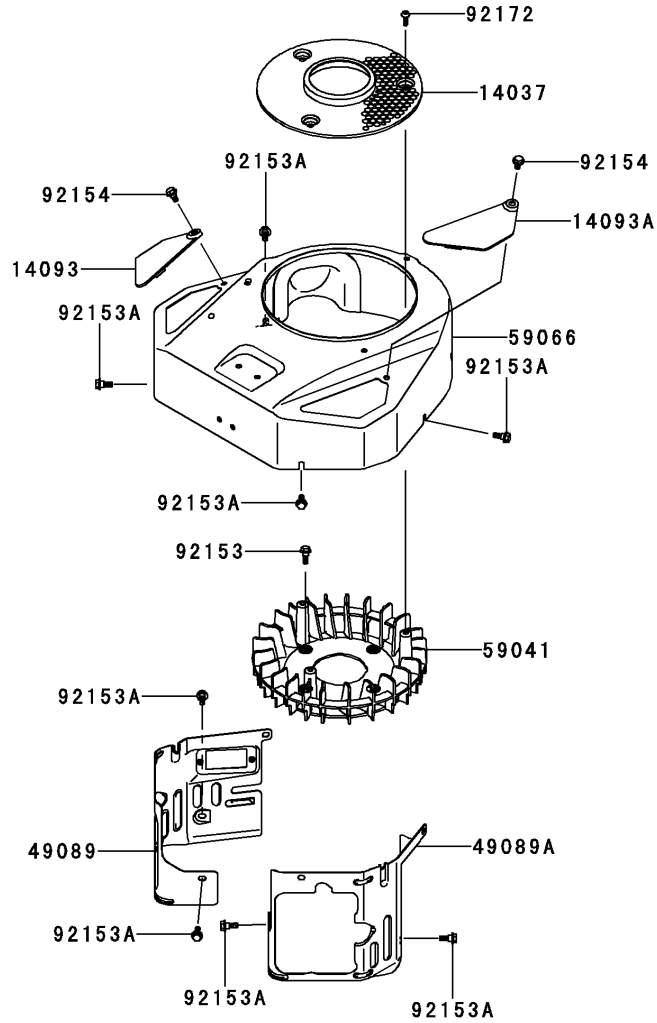

B-07. COOLING-EQUIPMENT

Ref. No.	Part No.	Description	Quantity	
				E
14037	14037-0754	SCREEN	1	
14093	14093-0358	COVER,CYL #1	1	
14093A	14093-0359	COVER,CYL #2	1	
49089	49089-7085-753	SHROUD-ENGINE	1	
49089A	49089-7086-753	SHROUD-ENGINE	1	
59041	59041-0012	FAN	1	
59066	59066-0765-753	HOUSING-FAN,GRAY	1	
92153	92153-7007	BOLT,FLANGED,6X16	4	
92153A	92153-7043	BOLT,6X12	8	
92154	92154-1119	BOLT	2	
92172	92172-0896	SCREW,5X19.6	3	

E0160-B851A

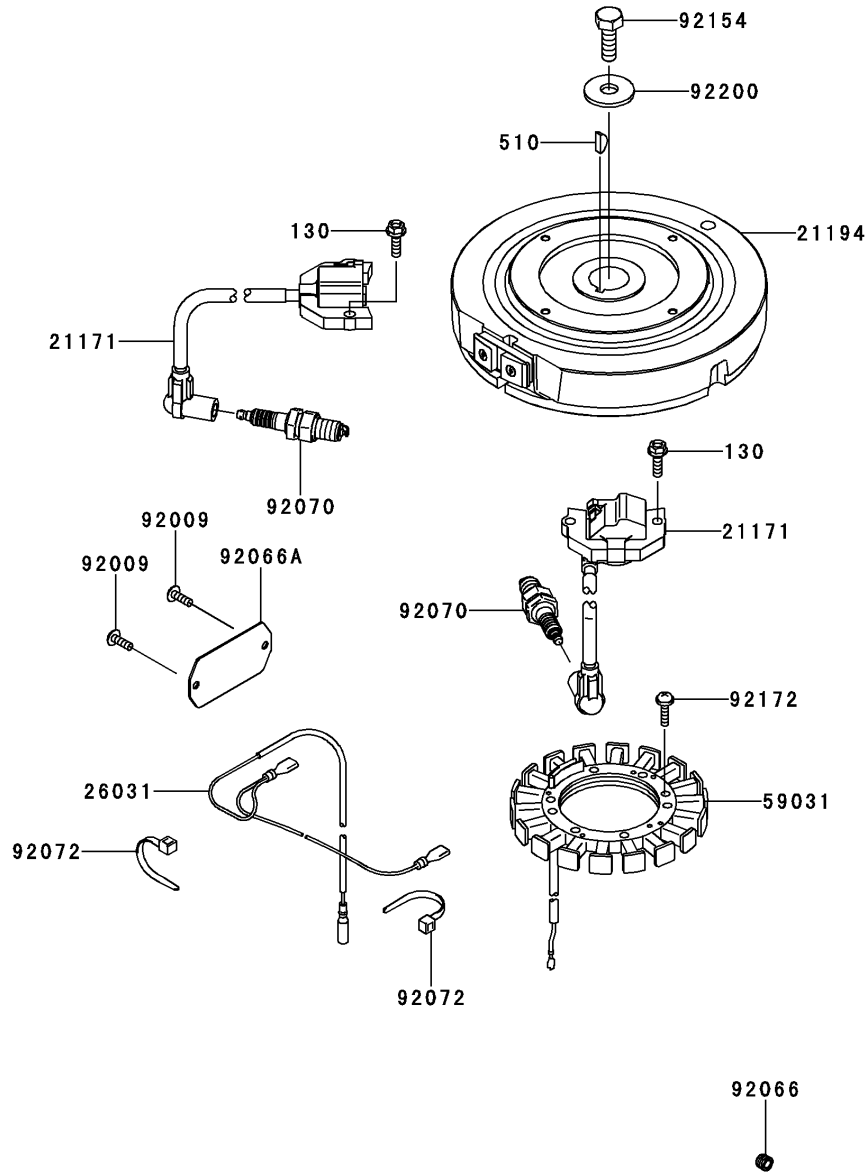

B-08. ELECTRIC-EQUIPMENT

Ref. No.	Part No.	Description	Quantity
			E
21171	21171-0740	COIL-ASSY-IGNITION	2
21194	21194-0020	FLYWHEEL-COMP	1
26031	26031-7040	HARNES	1
59031	59031-7002	COIL-CHARGING	1
92009	92009-2308	SCREW	2
92066	92066-0762	PLUG	1
92066A	92066-7005	PLUG	1
92070	92070-7004	PLUG-SPARK,BPR4ES(NGK),SOLID	2
92072	92072-7003	BAND	2
92154	92154-7003	BOLT,12X30	1
92172	92172-7018	SCREW,5X20	4
92200	92200-7002	WASHER	1
130	130AA0620	BOLT-FLANGED,6X20	4
510	510A5100	KEY-WOODRUFF	1

E0170-A759B

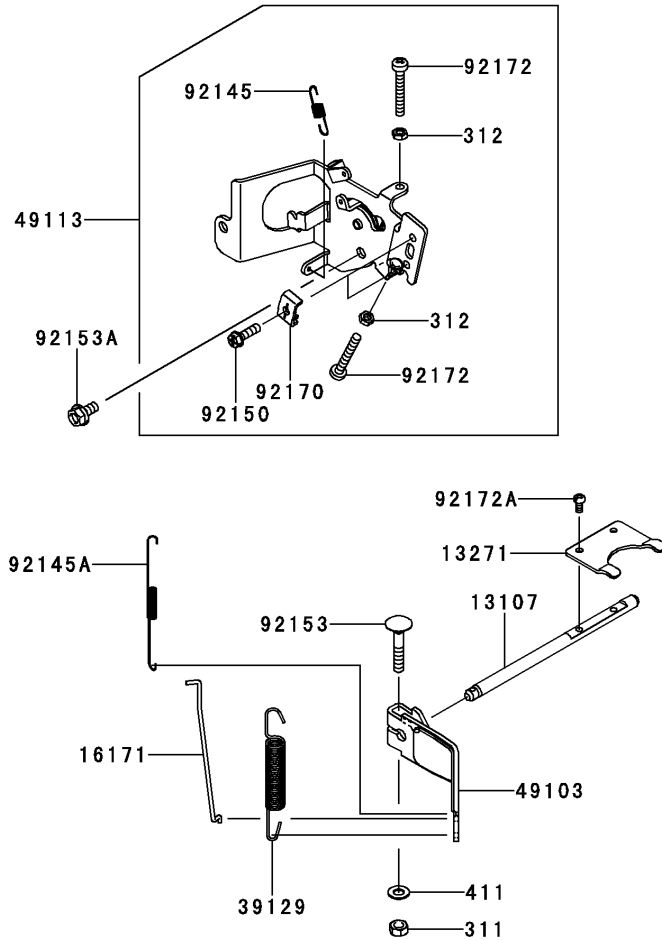

B-09. CONTROL-EQUIPMENT

Ref. No.	Part No.	Description	Quantity	
				E
13107	13107-7049	SHAFT	1	
13271	13271-7038	PLATE	1	
16171	16171-7025	LINK	1	
39129	39129-0725	SPRING-GOVERNOR	1	
49103	49103-7017	ARM-GOVERNOR	1	
49113	49113-0725	PANEL-COMP-CONTROL	1	
92145	92145-7004	SPRING	1	
92145A	92145-7057	SPRING	1	
92150	92150-2182	BOLT,5X18	2	
92153	92153-7033	BOLT,6X35	1	
92153A	92153-7043	BOLT,6X12	1	
92170	92170-7001	CLAMP	2	
92172	92172-0792	SCREW,5X35	2	
92172A	92172-0870	SCREW,4X8	2	
311	311BA0600	NUT-HEX,6MM	1	
312	312AA0500	NUT-HEX,5MM	2	
411	411AA0600	WASHER-PLAIN,6MM	1	

E0180-B104A

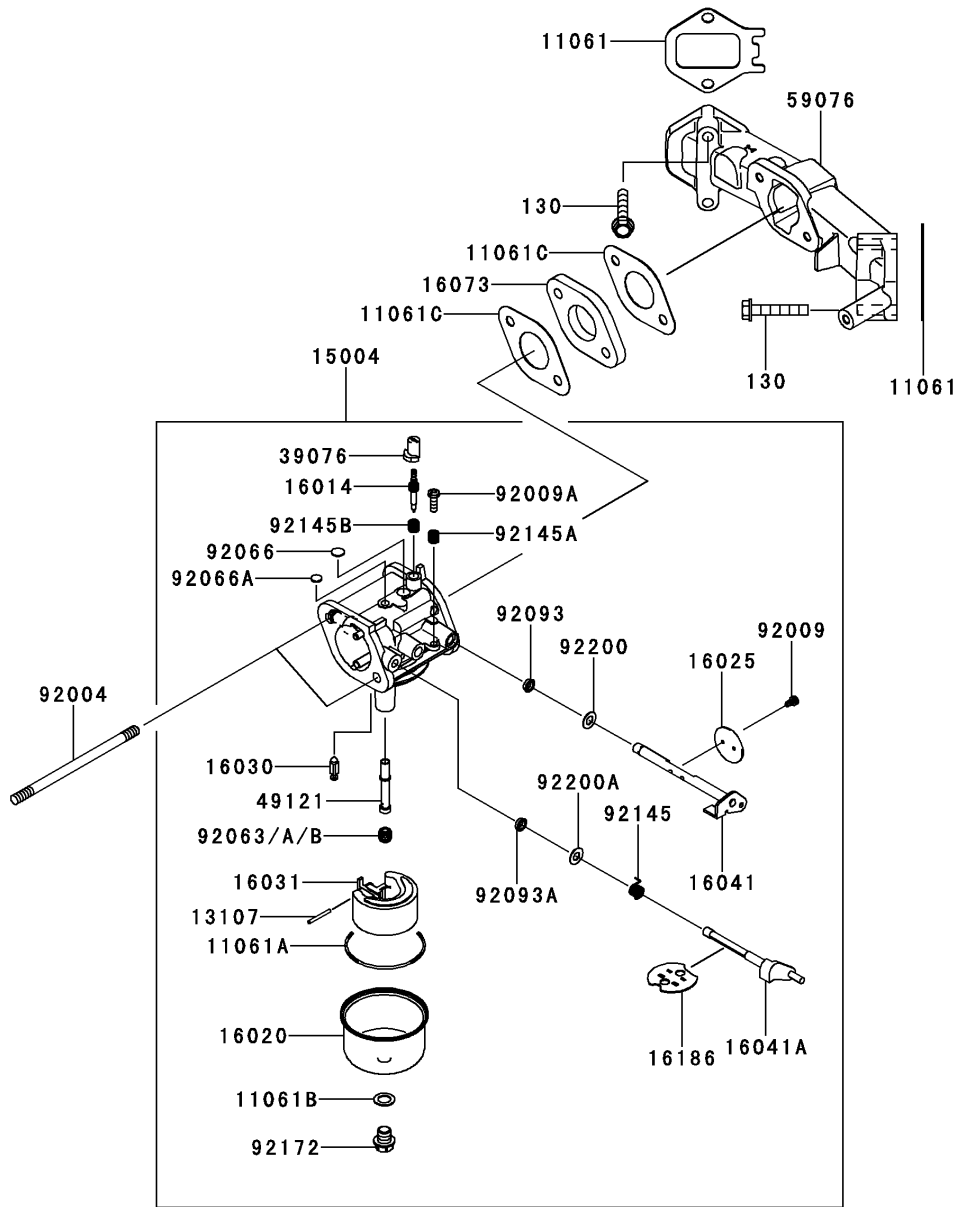

B-10. CARBURETOR

Ref. No.	Part No.	Description	Quantity
			E
11061	11061-0877	GASKET,MANIFOLD	2
11061A	11061-7009	GASKET,CHAMBER	1
11061B	11061-7010	GASKET,SCREW	1
11061C	11061-7096	GASKET,INSULATOR	2
13107	13107-7018	SHAFT	1
15004	15004-0825	CARBURETOR-ASSY	1
16014	16014-7011	SCREW-PILOT AIR	1
16020	16020-7003	CHAMBER-FLOAT	1
16025	16025-7006	VALVE-THROTTLE	1
16030	16030-7003	VALVE-FLOAT	1
16031	16031-7002	FLOAT	1
16041	16041-7018	SHAFT-CARBURETOR,THROTTLE	1
16041A	16041-7049	SHAFT-CARBURETOR,CHOKE	1
16073	16073-7007	INSULATOR	1
16186	16186-7001	VALVE-ASSY-CHOKE	1
39076	39076-7001	LIMITER	1
49121	49121-7020	NOZZLE-MAIN	1
59076	59076-7020	MANIFOLD-INTAKE	1
92004	92004-2149	STUD,6X98	2
92009	92009-2083	SCREW	2
92009A	92009-2349	SCREW	1
92063	92063-7046	JET-MAIN,#100,3280FT (OPTION)	1
92063A	92063-7047	JET-MAIN,#098,6560FT (OPTION)	1
92063B	92063-7156	JET-MAIN,#102	1
92066	92066-2204	PLUG	1
92066A	92066-2244	PLUG	1
92093	92093-0593	SEAL	1
92093A	92093-0594	SEAL	1
92145	92145-0931	SPRING	1
92145A	92145-1579	SPRING	1
92145B	92145-7015	SPRING	1
92172	92172-7002	SCREW	1
92200	92200-0848	WASHER	1
92200A	92200-2061	WASHER,9.8X5.5X1.0	1
130	130AA0635	BOLT-FLANGED,6X35	4

E0190-B362A

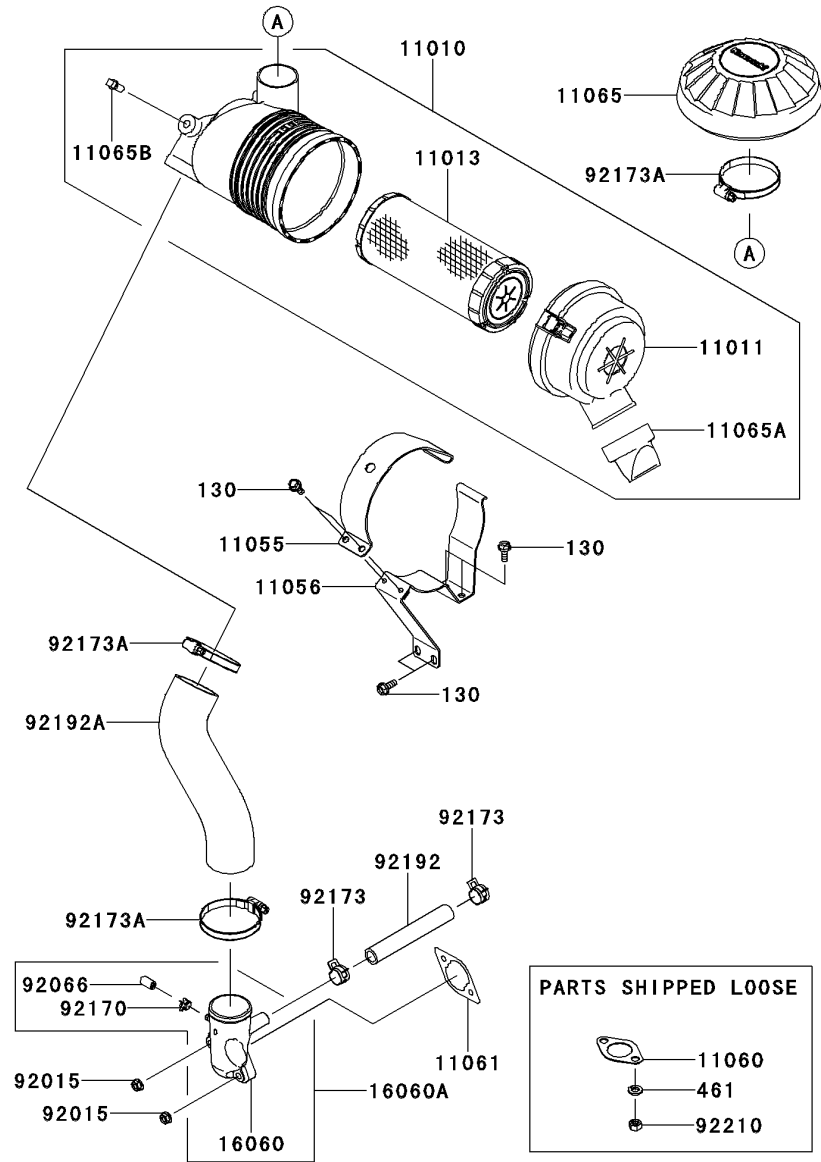

B-11. AIR-FILTER/MUFFLER

Ref. No.	Part No.	Description	Quantity
			E
11010	11010-7031	FILTER-ASSY-AIR	1
11011	11011-7058	CASE-AIR FILTER	1
11013	11013-7048	ELEMENT-AIR FILTER	1
11055	11055-7024-9H	BRACKET	1
11056	11056-7008-9H	BRACKET	1
11060	11060-7016	GASKET,MUFFLER	2
11061	11061-7095	GASKET,AIR CLEANER	1
11065	11065-7026	CAP	1
11065A	11065-7031	CAP	1
11065B	11065-7032	CAP	1
16060	16060-0740	PIPE-INTAKE	1
16060A	16060-0742	PIPE-INTAKE	1
92015	92015-1367	NUT,FLANGED,6MM	2
92066	92066-0095	PLUG	1
92170	92170-2042	CLAMP	1
92173	92173-7003	CLAMP	2
92173A	92173-7009	CLAMP	3
92192	92192-7146	TUBE,12.6X18.6X118	1
92192A	92192-7154	TUBE,A/C	1
92210	92210-7027	NUT,M8	4
130	130AA0616	BOLT-FLANGED,6X16	6
461	461DA0800	WASHER-SPRING,8MM	4

E0210-A733A

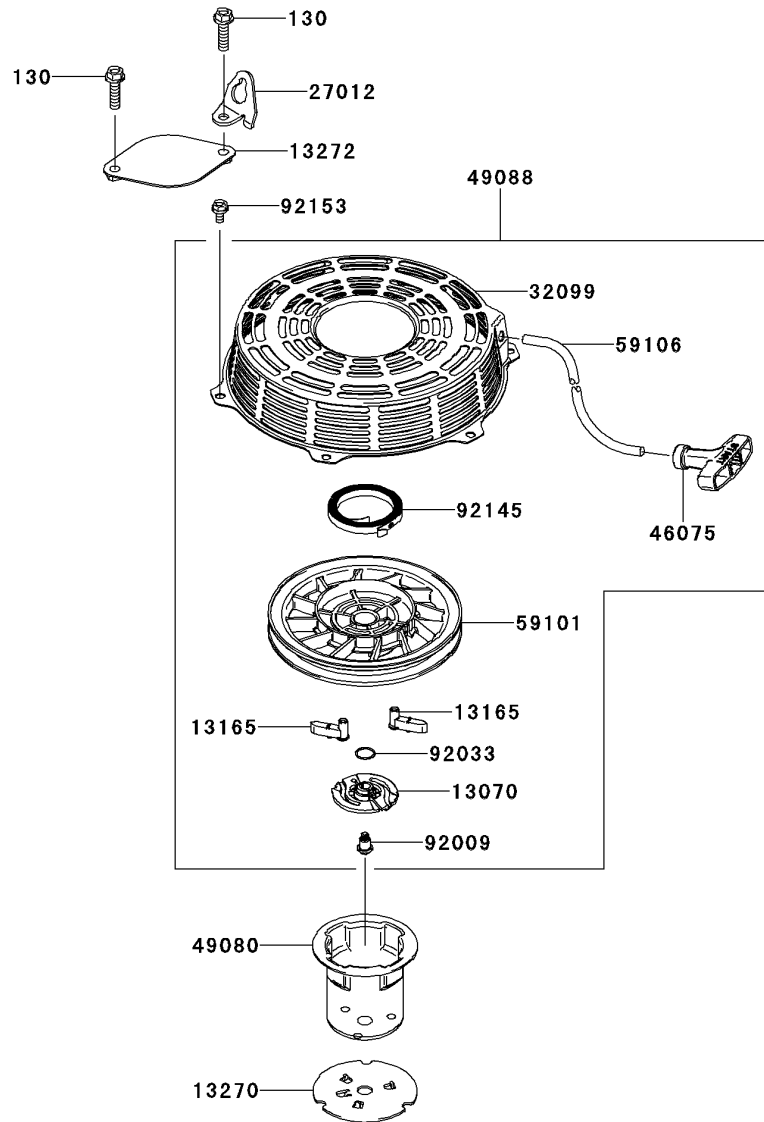

B-13. STARTER

Ref. No.	Part No.	Description	Quantity
			E
13070	13070-0742	GUIDE	1
13165	13165-2092	PAWL,RECOIL STARTER	2
13270	13270-7007	PLATE	1
13272	13272-7014	PLATE	1
27012	27012-7008	HOOK	1
32099	32099-0732	CASE	1
46075	46075-2106	GRIP,RECOIL STARTER	1
49080	49080-7002	PULLEY-STARTING	1
49088	49088-0010	STARTER-RECOIL	1
59101	59101-2110	REEL,RECOIL STARTER	1
59106	59106-2157	ROPE,5X1500	1
92009	92009-2382	SCREW	1
92033	92033-2175	RING-SNAP	1
92145	92145-7063	SPRING	1
92153	92153-7043	BOLT,6X12	3
130	130BA0830	BOLT-FLANGED,8X30	2

F0290-C041A

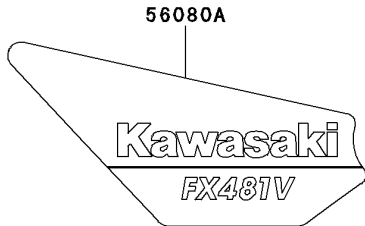
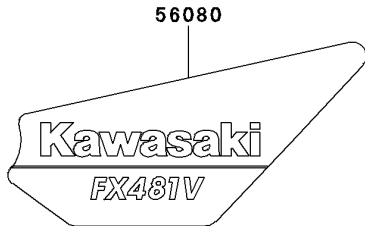
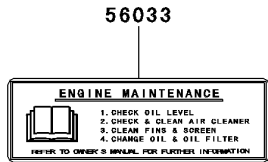

C-03. LABEL

Ref. No.	Part No.	Description	Quantity
			E
56014	56014-0005	EMBLEM	1
56033	56033-7001	LABEL-MANUAL	1
56071	56071-0216	LABEL-WARNING	1
56080	56080-0867	LABEL-BRAND,FX481V/CYL #1	1
56080A	56080-0868	LABEL-BRAND,FX481V/CYL #2	1

FX481V- S01

NUMERICAL PARTS INDEX

Part No.	Fig No.	Part No.	Fig No.	Part No.	Fig No.	Part No.	Fig No.	Part No.	Fig No.	Part No.	Fig No.
11004-7027	B-03	13271-7038	B-09	49088-0010	B-13	92066-2223	B-03	92192-7154	B-11		
11008-7050	B-03	13272-1374	B-03	49089-7085-753	B-07	92066-2244	B-10	92200-0848	B-10		
11008-7051	B-03	13272-7011	B-06	49089-7086-753	B-07	92066-7005	B-08	92200-0945	B-05		
11010-7031	B-11	13272-7014	B-13	49103-7017	B-09	92070-7004	B-08	92200-2061	B-10		
11011-7058	B-11	14037-0754	B-07	49113-0725	B-09	92072-7003	B-08	92200-2151	B-05		
11013-7048	B-11	14075-0037	B-06	49118-0809	B-05	92093-0593	B-10	92200-7002	B-08		
11022-0038	B-03	14091-7064	B-03	49120-0731	B-03	92093-0594	B-10	92200-7048	B-05		
11022-0710	B-03	14093-0358	B-07	49121-7020	B-10	92104-0007	B-03	92210-7027	B-11		
11055-7009	B-05	14093-0359	B-07	510A5100	B-08	92140-7003	B-06				
11055-7024-9H	B-11	15004-0825	B-10	555A0420	B-06	92140-7005	B-05				
11056-7008-9H	B-11	16014-7011	B-10	56014-0005	C-03	92145-0931	B-10				
11060-7016	B-11	16020-7003	B-10	56033-7001	C-03	92145-1579	B-10				
11061-0877	B-10	16025-7006	B-10	56071-0216	C-03	92145-1653	B-05				
11061-7009	B-10	16030-7003	B-10	56080-0867	C-03	92145-1658	B-06				
11061-7010	B-10	16031-7002	B-10	56080-0868	C-03	92145-7004	B-09				
11061-7083	B-03	16041-7018	B-10	59031-7002	B-08	92145-7015	B-10				
11061-7094	B-03	16041-7049	B-10	59041-0012	B-07	92145-7057	B-09				
11061-7095	B-11	16060-0740	B-11	59066-0765-753	B-07	92145-7063	B-13				
11061-7096	B-10	16060-0742	B-11	59071-0733	B-03	92150-2182	B-09				
11065-7026	B-11	16073-7007	B-10	59076-7020	B-10	92151-7017	B-04				
11065-7031	B-11	16126-7020	B-03	59101-2110	B-13	92152-1689	B-05				
11065-7032	B-11	16154-7010	B-06	59106-2157	B-13	92153-7007	B-06				
12004-7009	B-05	16154-7011	B-06	59231-0712	B-06	92153-7007	B-07				
12005-0735	B-05	16171-7025	B-09	670B2011	B-03	92153-7033	B-09				
12009-7001	B-05	16186-7001	B-10	670D2016	B-06	92153-7043	B-03				
12011-2056	B-05	172BA0822	B-03	92004-2149	B-10	92153-7043	B-06				
12016-0040	B-05	21171-0740	B-08	92009-2083	B-10	92153-7043	B-07				
12032-7001	B-05	21194-0020	B-08	92009-2303	B-12	92153-7043	B-09				
13001-7031	B-04	26031-7040	B-08	92009-2308	B-08	92153-7043	B-13				
13002-7001	B-04	27012-0721	B-03	92009-2349	B-10	92153-7054	B-03				
13008-7006	B-04	27012-7008	B-13	92009-2382	B-13	92153-7100	B-05				
13025-7010	B-04	311BA0600	B-09	92015-1367	B-11	92154-1119	B-07				
13029-7011	B-04	312AA0500	B-09	92033-0725	B-04	92154-1267	B-05				
13031-0814	B-04	312AA0600	B-05	92033-0727	B-05	92154-7003	B-08				
13070-0742	B-13	32099-0732	B-13	92033-2175	B-13	92170-2009	B-12				
13070-7017	B-05	32155-7003	B-03	92043-0858	B-03	92170-2042	B-11				
130AA0616	B-11	39076-7001	B-10	92043-1263	B-03	92170-7001	B-09				
130AA0620	B-08	39129-0725	B-09	92049-7001	B-03	92172-0792	B-09				
130AA0635	B-10	411AA0600	B-09	92049-7016	B-03	92172-0870	B-03				
130BA0625	B-03	42036-7015	B-12	92049-7019	B-03	92172-0870	B-09				
130BA0830	B-13	42036-7021	B-05	92049-7028	B-03	92172-0896	B-07				
130CA0870	B-03	46075-2106	B-13	92063-7046	B-10	92172-7002	B-10				
13107-7018	B-10	461DA0800	B-11	92063-7047	B-10	92172-7018	B-08				
13107-7049	B-09	49015-0019	B-03	92063-7156	B-10	92173-1000	B-12				
13116-7008	B-05	49019-7001	B-12	92066-0095	B-11	92173-7003	B-11				
13165-2092	B-13	49040-7008	B-12	92066-0761	B-03	92173-7009	B-11				
13251-7021	B-04	49065-7006	B-06	92066-0762	B-03	92192-1551	B-12				
13270-7007	B-13	49065-7007	B-06	92066-0762	B-08	92192-1560	B-12				
13271-7007	B-05	49078-7002	B-05	92066-0774	B-06	92192-7146	B-11				
13271-7021	B-05	49080-7002	B-13	92066-2204	B-10	92192-7148	B-12				

Kawasaki Heavy Industries, Ltd.

Motorcycle & Engine Company

Part No. 99907-6977-01